

# MOXA

## NPort IA5150/5250 Series Quick Installation Guide

Third Edition, January 2006

### 1. Overview

NPort IA device servers deliver easy and reliable serial-to-Ethernet connectivity for the industrial automation market. The servers support several operation modes—TCP Server, TCP Client, UDP, Real COM, Pair Connection, and Ethernet Modem—ensuring the compatibility of network software, and are an ideal choice for connecting RS-232/422/485 serial devices, such as PLCs, sensors, meters, motors, drives, barcode readers, and operator displays. NPort IA device servers come with a compact and rugged DIN-Rail mountable casing.

### 2. Package Checklist

Before installing NPort IA device servers, verify that the package contains the following items:

- 1 NPort IA Serial Device Server
- Documentation & Software CD
- NPort IA Series Quick Installation Guide

#### Optional Accessories

- DR-4524 45W/2A DIN-Rail 24 VDC Power Supply with universal 85 to 264 VAC input
- DR-75-24 75W/3.2A DIN-Rail 24 VDC Power Supply with universal 85 to 264 VAC input
- DR-120-24 120W/5A DIN-Rail 24 VDC Power Supply with 88 to 132 VAC/176 to 264 VAC input by switch

Notify your sales representative if any of the above items is missing or damaged.

### 3. Hardware Introduction

NPort IA device servers are used to control RS-232/422/485 devices for industrial automation environments. Six of the models have 1 RS-232/422/485 serial port. NPort IA5150, NPort IA5150I, NPort IA5150-M-SC, NPort IA5150I-M-SC, NPort IA5150-S-SC, and NPort IA5150I-S-SC have 1 male DB9 port for the RS-232 interface, and a 5-pin terminal block for the RS-422/485 interface (only one port can be used at a time). One model has 2 RS-232/422/485 serial ports. NPort IA5250 has two male DB9 ports for all interfaces.

P/N: 1802051500200

#### NPort IA5150 Series Appearance

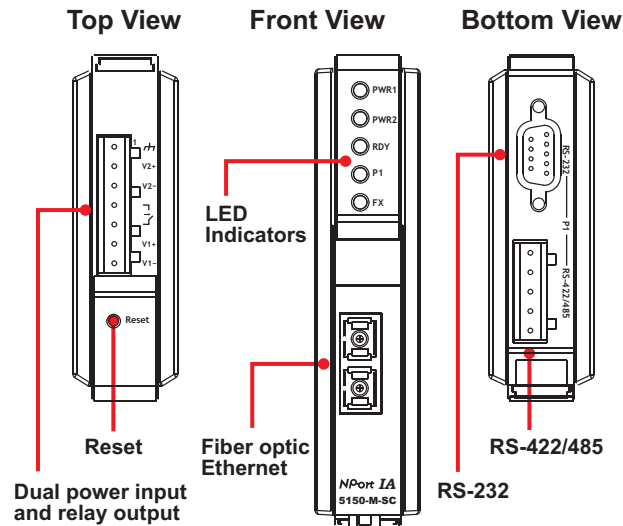

#### NPort IA5250 Appearance

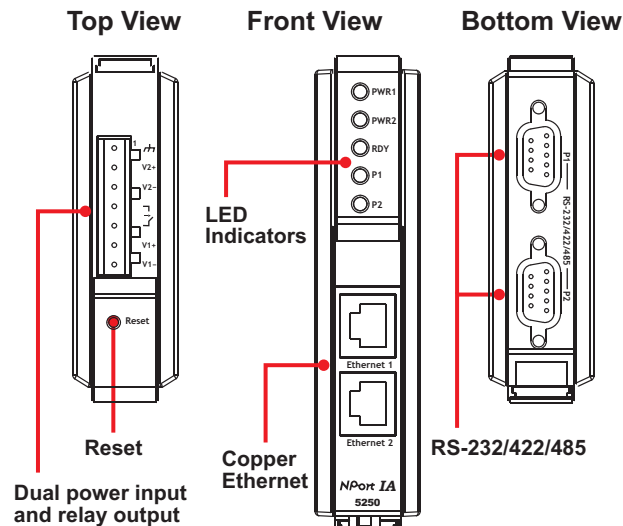

**Reset Button**—Press the *Reset button* continuously for *5 sec* to load *factory defaults*. Use a pointed object, such as a straightened paper clip or toothpick, to press the reset button. This will cause the Ready LED to blink on and off. The factory defaults will be loaded once the Ready LED stops blinking (after about 5 seconds). At this point, you should release the reset button.

#### NPort IA LED Indicators (front panel)

LED Name	LED Color	LED Function
PWR1, PWR2	red	Power is being supplied to power input PWR1, PWR2.
RDY	red	Steady on: Power is on and NPort IA is booting up.
		Blinking: Indicates an IP conflict, the DHCP or BOOTP server did not respond properly, or a relay output occurred.
	green	Steady on: Power is on and NPort IA is functioning normally.
	off	The device server has been located by Administrator's Location function.
Ethernet	orange	Power is off, or power error condition exists.
	green	10 Mbps Ethernet connection.
	off	100 Mbps Ethernet connection.
P1, P2	orange	Ethernet cable is disconnected, or has a short.
	green	Serial port is receiving data.
	off	Serial port is transmitting data.
FX	orange	No data is being transmitted or received through the serial port.
		Steady on: Ethernet fiber connection, but port is idle.
		Blinking: Fiber port is transmitting or receiving data.

### 4. Hardware Installation Procedure

**STEP 1:** After removing NPort IA from the box, the first thing you should do is connect the power adaptor. Connect the 12-48 VDC power line with NPort IA's terminal block, or connect the DIN-Rail power supply with NPort IA's terminal block.

**STEP 2:** Connect NPort IA to a network. Use a standard straight-through Ethernet cable to connect to a Hub or Switch. When setting up or testing NPort IA, you might find it convenient to connect directly to your computer's Ethernet port. In this case, use a cross-over Ethernet cable.

**STEP 3:** Connect NPort IA's serial port to a serial device.

**STEP 4:** NPort IA is designed to be attached to a DIN-Rail or mounted on a wall. The two sliders on NPort IA's rear panel serve a dual purpose. For wall mounting, both sliders should be extended. For DIN-Rail mounting, start with one slider pushed in, and the other slider extended. After placing the NPort IA on the DIN-Rail, push the extended slider in to lock the device server to the rail. The two placement options are illustrated in the accompanying figures.

### Wall Mount

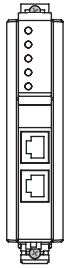

### DIN-Rail

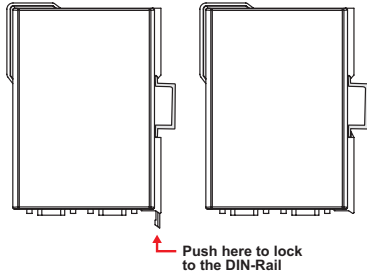

## 5. Software Installation Information

To install **NPort Administration Suite**, insert the **Document & Software CD** into your computer's CD-ROM drive. Once the installation window opens, click on the **Installation Administration Suite** button, and then follow the instructions on the screen. To view detailed information about **NPort IA Administration Suite**, click on the **Documents** button, and then select NPort IA5150/5250 Series User's Manual to open the pdf version of this user's manual.

## 6. Pin Assignments and Cable Wiring

### RS-232/422/485 (Male DB9) Pinouts

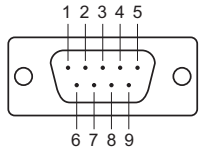

PIN	RS-232	RS-422/ RS-485 (4W)	RS-485 (2W)
1	DCD	TxD-(A)	---
2	RXD	TxD+(B)	---
3	TXD	RxD+(B)	Data+(B)
4	DTR	RxD-(A)	Data-(A)
5	GND	GND	GND
6	DSR	---	---
7	RTS	---	---
8	CTS	---	---
9	---	---	---

### 4W/2W RS-485/RS-422 (Terminal Block) Pinouts

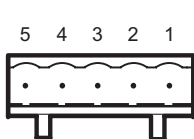

PIN	2W	4W
1	---	TxD+(B)
2	---	TxD-(A)
3	Data+(B)	RxD+(B)
4	Data-(A)	RxD-(A)
5	---	GND

Four cables are available as optional accessories that can be used to connect NPort IA to RS-232 serial devices. For your convenience, we show precise cable wiring diagrams for each of the two cables.

### Female DB9 to Male DB9

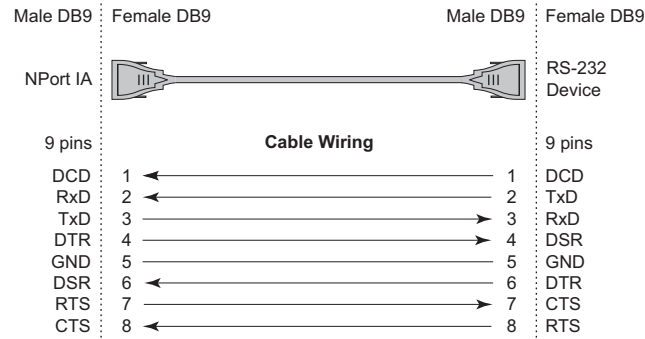

### Female DB9 to Male DB25

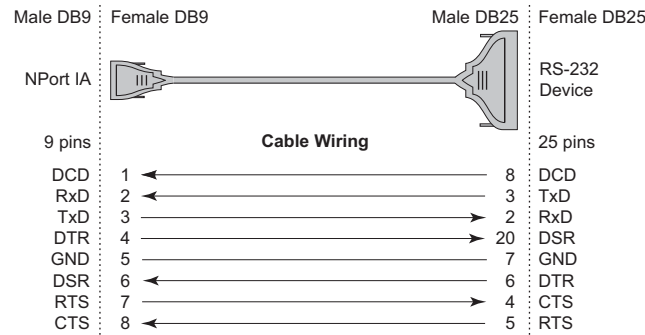

## 7. Specifications

Power requirements	NPort IA5150:	12 to 48 VDC, 360 mA at 12V (max.)
	NPort IA5150I:	12 to 48 VDC, 420 mA at 12V (max.)
	NPort IA5150-S-SC:	12 to 48 VDC, 470 mA at 12 V (max.)
	NPort IA5150I-S-SC:	12 to 48 VDC, 490 mA at 12V (max.)
	NPort IA5150-M-SC:	12 to 48 VDC, 500 mA at 12 V (max.)

NPort IA5150I-M-SC: 12 to 48 VDC, 510 mA at 12V (max.)

NPort IA5250: 12 to 48 VDC, 440 mA at 12 V (max.)

Operating temp.	0 to 55°C (32 to 131°F)
Operating humidity	5 to 95% RH
Dimensions (W×D×H)	29 × 89.2 × 118.5 mm 1.14 × 3.51 × 4.67 in
Surge protection	15 KV ESD for all signals
Magnetic isolation	1.5 KV for Ethernet
Power line protection	4 KV Burst (EFT), EN61000-4-4 2 KV Surge, EN61000-4-5
Regulatory approvals	FCC Class A, CE Class A, UL, CUL, TÜV

Copyright © 2005  
Moxa Technologies Co., Ltd.  
All rights reserved.

Reproduction without permission is prohibited.

**MOXA**

Tel: +886-2-8919-1230 [www.moxa.com](http://www.moxa.com)  
Fax: +886-2-8919-1231 [support@moxa.com.tw](mailto:support@moxa.com.tw)